

SHORT STROKE PNEUMATIC CYLINDERS - LO-Profile® SERIES A-ETI-PM

Double Acting-Single Ended Pistons-End Trepanned Inlets-Pocket Mounted

NOTE 1: 6-32 Slotted Round Head Machine Screws With Lengths To 3 Inches Are Available From Most Industrial Supply Distributors.

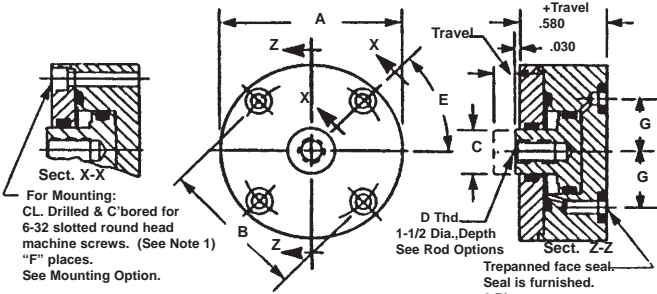

PRODUCT DETAILS

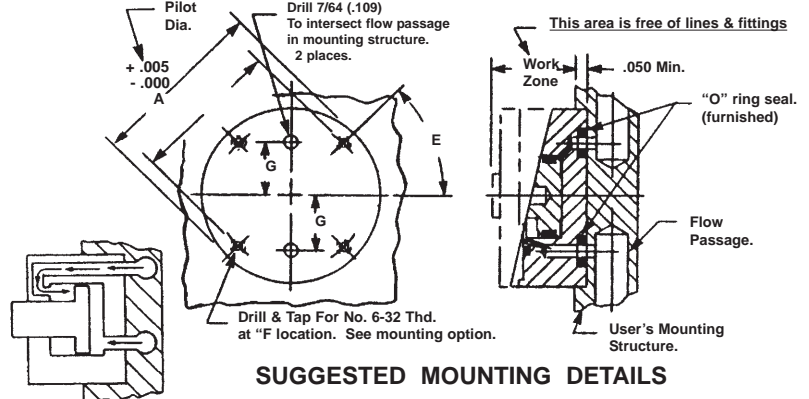

SUGGESTED MOUNTING DETAILS

Pictorial

BASIC PART No.	O.D. A	BOLT CIRCLE B	ROD DIA. C	ROD THD. D	DEG. E	NO. PLCS. F	DIM. G	WR. FLATS H	DEPTH J	LENGTH K	OFF SET L	REAM M	WIDTH N	WIDTH O	PISTON O.D. (IN.)	EXTEND PISTON AREA (SQ. IN)	RETRACT PISTON AREA (SQ. IN)
6014(-)	1.000	0.688	0.250	4-40	00	2	.330	.188	0.305	.385	.141	0.094	0.063	0.156	0.450	0.159	0.110
6015(-)	1.250	0.938	0.313	10-32	00	2	.392	.250	0.305	.385	.141	0.094	0.094	0.156	0.575	0.260	0.183
6016(-)	1.500	1.188	0.375	10-32	00	2	.464	.281	0.406	.486	.188	0.125	0.125	0.188	0.700	0.385	0.275
6017(-)	1.750	1.438	0.500	1/4-28	45	4	.590	.375	0.610	.690	.281	0.188	0.188	0.250	0.950	0.709	0.513
6018(-)	2.000	1.688	0.625	5/16-24	45	4	.714	.500	0.610	.690	.281	0.188	0.188	0.250	1.200	1.131	0.824
6019(-)	2.250	1.938	0.625	5/16-24	45	4	.840	.500	0.610	.690	.281	0.188	0.188	0.250	1.450	1.651	1.344
6020(-)	2.500	2.188	0.625	5/16-24	45	4	.965	.500	0.610	.690	.281	0.188	0.188	0.250	1.700	2.270	1.963

(thrust force = area times pressure)

ORDERING INFORMATION:

HOW TO ORDER BASIC CYLINDERS

A BASIC PART NUMBER consists of a four digit number followed by a dash number to indicate piston travel in increments of 1/10 (0.100) inch. Travel to -20(2.000) is standard. Please consult the factory for longer travels.

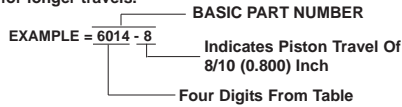

HOW TO ORDER CYLINDERS WITH OPTIONS

Add options to the BASIC PART NO. as suffixes in any order.

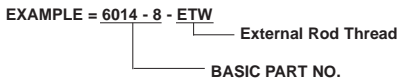

HOW TO ORDER CYLINDERS WITH STAINLESS STEEL PISTONS

Add the letter -S as a prefix to the BASIC PART NO. Add 25% to the BASE PRICE.

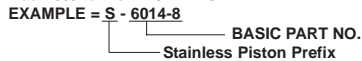

HOW TO ORDER ALL STAINLESS STEEL CYLINDERS

Add the letter -SS as a prefix to the BASIC PART NO. Add 40% to the BASE PRICE.



HOW TO ORDER METRIC CYLINDERS

A BASIC PART NO. FOR METRIC CYLINDERS consists of a four or five number from the with a prefix "M" and a suffix to indicate travel in millimeters. See inside rear cover for piston travel conversion. There is no added cost.

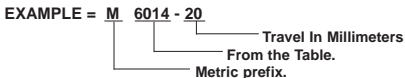

SPECIFICATIONS:
SERVICE, PLANT AIR
M.O.P., 300 PSI
TEMPERATURE, -40°F to +250°F

MATERIALS:
BODY & COVER, ALUMINUM ALLOY
PISTON, ALUMINUM ALLOY
SEALS, BUNA "N" O RINGS
FASTENERS, ALLOY STEEL

SEE BELOW ON "HOW TO ORDER OPTIONAL MATERIALS"

NOTES:

Dimensions are nominal in U.S. CUSTOMARY specifications. Metric cylinders are dimensionally equivalent except for conversion in mounting details where, threads, fasteners, clearance holes & counterbores are to metric standards. See inside back cover for a table of metric fastener conversion. There is no added cost for metric cylinders. An air/oil mist unit is recommended for internal lubrication. Where such units are not practical, service kits including seals and factory approved lubricant are available. Spring force for basic cylinders is sufficient to fully retract pistons. Inquiries regarding modifications to BASIC CYLINDERS are always welcome.

OPTIONAL MOUNTING STYLE:

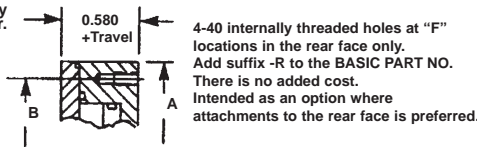

HOW TO ORDER CYLINDERS WITH VITON SEALS

Add suffix -V to the BASIC PART NO.

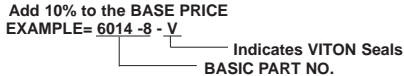

HOW TO ORDER VITON SERVICE KITS

Specify the BASIC PART NO. followed by the suffix -VSK

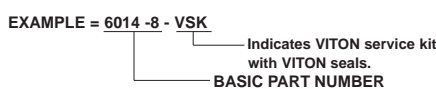

HOW TO ORDER BUNA "N" SERVICE KITS

Specify the BASIC PART NO. followed by suffix -SK.

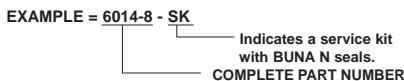

OPTIONAL ROD ENDS:

