

# SHORT STROKE HYDRAULIC CYLINDERS - HI-ENERGY® SERIES 1500-LS-ET-PM

Double Acting-Double Ended Pistons With Thru Thd.-End Trepan Ported-Pocket Mounted™

### PRODUCT DETAILS:

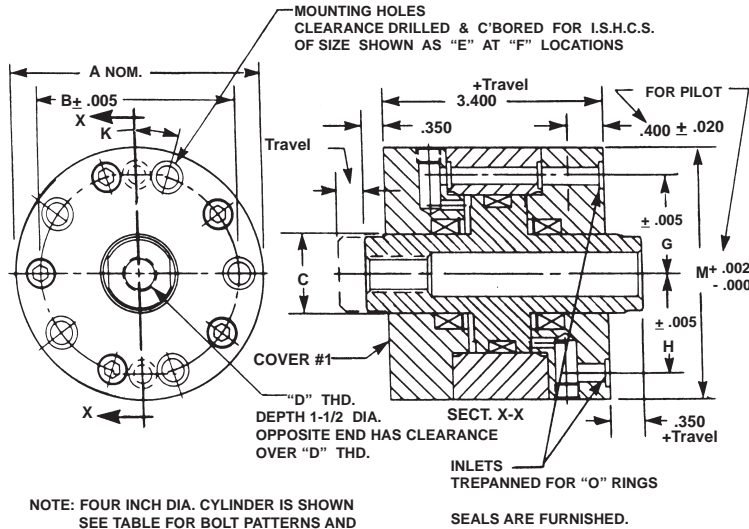

NOTE: FOUR INCH DIA. CYLINDER IS SHOWN  
SEE TABLE FOR BOLT PATTERNS AND  
RELATED DETAILS FOR OTHER SIZES

### SUGGESTED MOUNTING DETAILS:

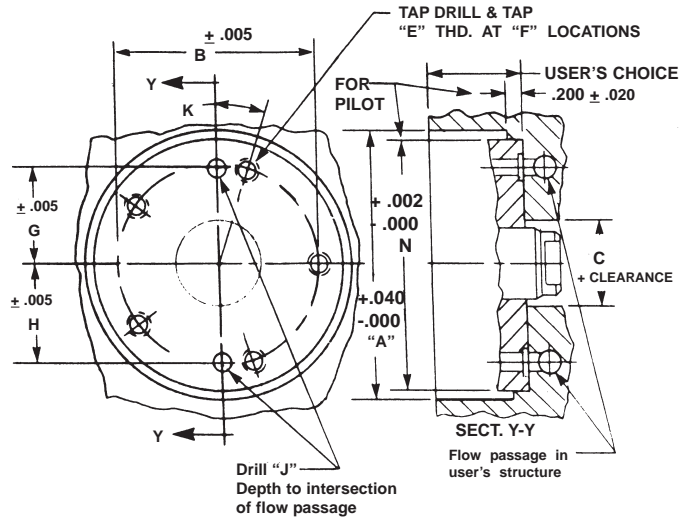

### SPECIFICATIONS:

SERVICE, HYDRAULIC OIL  
M.O.P., 1500 PSI  
TEMPERATURE -40 TO +200 deg. F  
MATERIALS;

BODY, STAINLESS STEEL  
GUIDE COVERS, BEARING BRONZE  
PISTONS, STAINLESS STEEL  
FASTENERS, ALLOY STEEL, I.S.H.C.S.  
ROD SEAL, LIP STYLE  
PISTON HEAD SEAL, "O" RING

BASIC PART NUMBER	O.D. A	B.C. B	ROD DIA. C	BOSS DIA. D	THD. E	NO. F	OFF SET G	OFF SET H	DRILL J	DEG. K	WF L	CYL. PILOT M	POCKET PILOT N	PISTON DIA. (IN.)	NET PISTON AREA (SQ.IN.)
S6172 (-)LS	3.000	2.375	0.875	1/2-20	1/4-28	4	1.148	1.148	0.188	22-1/2	0.688	2.974	2.976	1.750	1.804
S6173 (-)LS	4.000	3.188	1.250	5/8-18	5/16-24	5	1.571	1.571	0.281	18	1.000	3.974	3.976	2.500	3.681
S6174 (-)LS	5.000	4.188	1.500	3/4-16	3/8-24	6	2.070	2.070	0.281	15	1.250	4.974	4.976	3.500	7.854
S6175 (-)LS	6.000	5.188	2.000	1-14	3/8-24	8	2.571	2.571	0.281	11-1/4	1.625	5.974	5.976	4.500	12.762

Nom. Force (lbs) = Pressure (psi) times Area (sq.in.)

### Ordering Information:

#### HOW TO ORDER BASIC CYLINDERS:

A BASIC PART NUMBER consists of the letter "S" and four digits followed by a dash number to indicate piston travel in increments of 1/10 (0.100) inch followed by the suffix -LS. Travel to -40 (4.000) inch is standard.

EXAMPLE = S6172 - 8 - LS  
 S - BASIC PART NUMBER  
 6172 - Lip Seal Suffix  
 8 - Indicates Piston Travel  
 LS - Letter & Four digits from the table.

#### HOW TO ORDER CYLINDERS WITH OPTIONS:

Add options to the BASIC PART NUMBER as suffixes in any order.  
 EXAMPLE = S6172 - 8 - LS - ETW  
 S - BASIC PART NUMBER.  
 6172 - Lip Seal Suffix  
 8 - Indicates Piston Travel  
 LS - Letter & Four digits from the table.  
 ETW - Ext. Rod Thd. Option.

#### HOW TO ORDER METRIC VERSIONS:

A BASIC PART NUMBER FOR METRIC CYLINDERS consists of the letter "M" followed by a dash number to indicate travel in millimeters and the suffix -LS. Please see inside rear cover for metric thread and travel conversions. There is no added cost.

EXAMPLE = M-S6172 - 20 - LS  
 M - Metric Prefix  
 S6172 - Suffix  
 20 - Travel in Millimeters.  
 LS - From the table

#### HOW TO ORDER ALL STAINLESS STEEL CYLINDERS:

Add another letter "S" as a prefix to a BASIC PART NO.  
 Add 20% to the BASE PRICE  
 EXAMPLE = S-S6172 - 8 - LS  
 S - All Stainless Steel Prefix  
 S6172 - BASIC PART NUMBER  
 8 - Lip Seal Suffix  
 LS - Indicates Piston Travel

#### HOW TO ORDER CYLINDERS WITH SEALS FOR TEMPERATURES TO 275 DEGREES.

Add the letter "H" as a prefix to a BASIC PART NO.  
 Add 10% to the BASE PRICE.  
 EXAMPLE = H-S6172 - 8 - LS  
 H - High Temperature Seals  
 S6172 - BASIC PART NUMBER  
 8 - Lip Seal Suffix  
 LS - Indicates Piston Travel

#### HOW TO ORDER SERVICE KITS.

Specify the complete part number followed by the suffix "SK".  
 EXAMPLE = S6172 - 8 - LS - SK  
 S6172 - 8 - LS - Complete Part Number  
 SK - INDICATES SERVICE KIT

#### Mounting Option:

"E" INTERNALLY THREADED HOLES AT "F" LOCATIONS IN THE REAR MOUNTING FACE. ADD SUFFIX -R TO THE BASIC PART NUMBER. THERE IS NO ADDED COST. INTENDED AS AN OPTION WHERE ATTACHMENT FROM THE REAR IS PREFERRED.

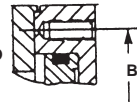

#### Rod End Option:

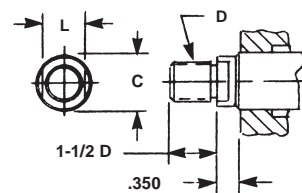

ROD END WITH EXTERNAL THREAD AND WRENCH FLATS EXTENDING FROM COVER #1. PISTON IS SOLID  
 ADD SUFFIX -ETW TO THE BASIC PART NUMBER.  
 ADD 8% TO THE BASE PRICE.

#### Wiper Option:

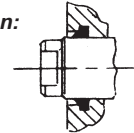

ROD WIPERS ARE OPTIONAL AND ARE INCORPORATED IN BOTH ENDS.  
 ADD SUFFIX -W TO THE BASIC PART NO.  
 ADD 4% TO THE BASE PRICE.

### NOTES:

DIMENSIONS ARE NOMINAL IN U.S. CUSTOMARY UNITS.  
 METRIC CYLINDERS ARE DIMENSIONALLY EQUIVALENT EXCEPT FOR CONVERSION IN MOUNTING DETAILS WHERE THREADS, FASTENERS, CLEARANCE HOLES & COUNTER-BORES ARE TO METRIC STANDARDS.  
 SEE INSIDE REAR COVER FOR A TABLE OF METRIC FASTENER CONVERSION.  
 THERE IS NO ADDED COST FOR THIS METRIC MODIFICATION.