

TECH DATA - "Z" AXIS TRANSPORTERS - SER. 2

MOUNTING

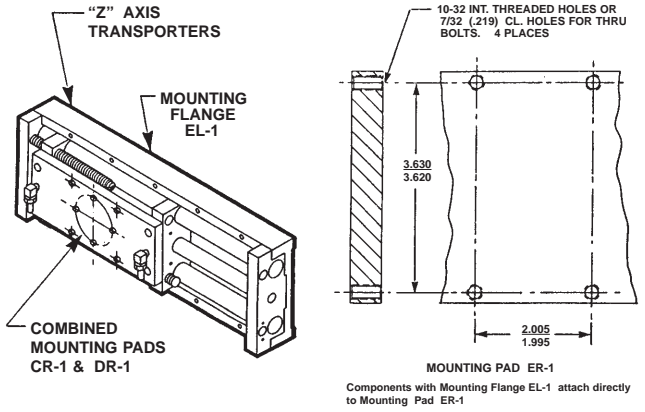

ADJUSTMENTS

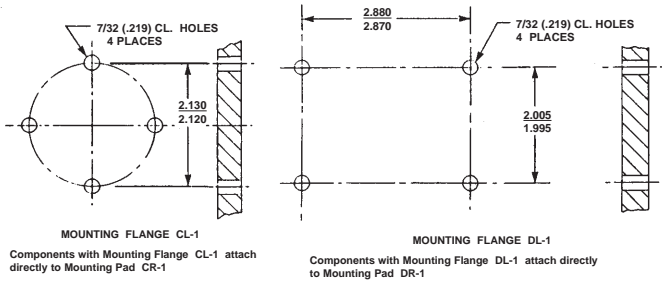
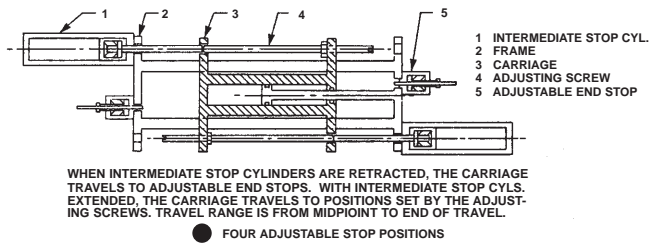
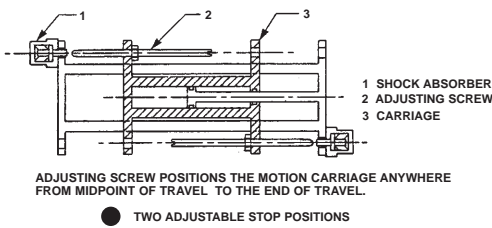

CONTROL

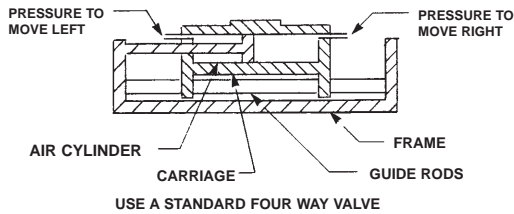

COMPONENT SELECTION

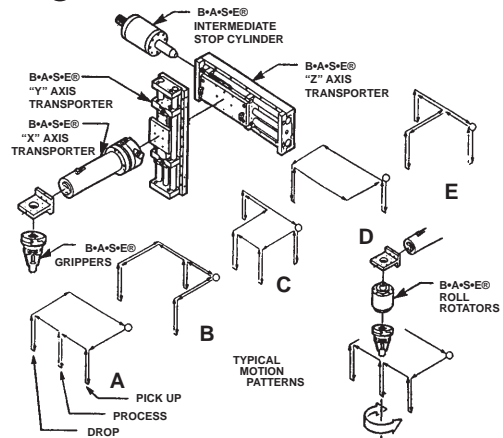

FITTINGS

TWO PIECE MONO-TAPER™ ELBOWS ARE SUPPLIED. MONO-TAPER™ FITTINGS ARE RUGGED, MINIATURE FITTINGS BASED ON S.A.E. 1/4-28 LT STANDARDS WHERE ALL THE TAPER IS INCORPORATED INTO THE FITTING. PORTS ARE 1/4-28 INTERNAL STRAIGHT THREADS.

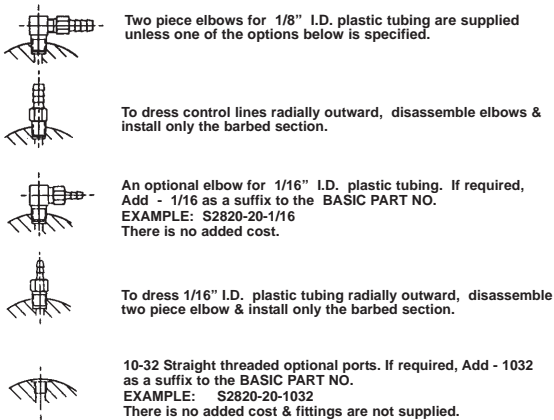

TYPICAL SYSTEM SCHEMATIC

