

Automation Basic Cylinders

A•B•C® AFT FACE MOUNTED

CONFIGURATIONS:

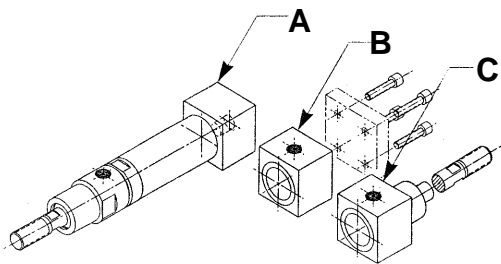

MOUNTING STYLE:

AFT FACE MOUNTED CYLINDERS provide a convenient method for mounting from the rear where bolts pass thru clearance holes in a mounting structure into threaded holes in the rear face of a cylinder. Cylinders operate properly in any position.

SPECIFICATIONS:

MATERIALS: Aluminum Alloy, Bronze and Steel.
SERVICE: Pneumatic and Hydraulic.
OPERATING PRESSURE RANGE: Vacuum to 300 P.S.I.
OPERATING TEMPERATURE RANGE: -20°F to 250°F.
SEALING ELEMENTS: Standard "O" Rings.

GENERAL NOTES:

All dimensions are nominal in U.S. CUSTOMARY units. Please consult the Factory for METRIC VERSIONS. A•B•C® is the registered trademark for MACK CORPORATION HEAVY DUTY AIR CYLINDERS. Developed and produced in the U.S.A. Please refer to page A20 for instructions in performing:
 Angular Port Adjustment.
 Complete Cylinder Servicing.
 Rod Seal & Bushing Service without disturbing the cylinder mounting or supply lines.

ORDERING INFORMATION:

HOW TO ORDER BASIC CYLINDERS
 A BASIC PART NUMBER consists of four digits followed by a dash number to indicate piston travel in increments of one inch.

EXAMPLE: 5000-12
 — BASIC PART NUMBER
 — TRAVEL IN INCHES
 — FOUR DIGITS FROM THE TABLE

HOW TO ORDER CYLINDERS WITH INTERNAL ROD THREADS
 Add the suffix -IT to the BASIC PART NUMBER. THERE IS NO ADDED COST.

EXAMPLE: 5000-12-IT
 — INTERNAL THREADS
 — BASIC PART NUMBER

HOW TO ORDER CYLINDERS WITH STAINLESS STEEL PISTON RODS
 Add the suffix -SS to the BASIC PART NUMBER. Add 25% to the BASE PRICE.

EXAMPLE: 5000-12-SS
 — STAINLESS STEEL ROD OPTION
 — BASIC PART NUMBER

HOW TO ORDER SERVICE KITS
 Add the suffix -SK to the FOUR DIGIT NUMBER.

EXAMPLE: 5000-SK
 — INDICATES SERVICE KIT
 — FOUR DIGITS FROM THE TABLE

CONFIGURATION A, Double Acting-Single Ended-Side & End Ports

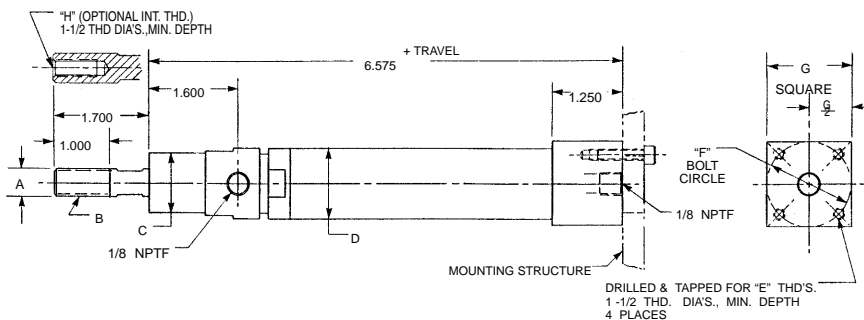

PART NO. & TRAVEL	CYLINDER BORE	A ROD DIA.	B EXTERNAL ROD THD.	C NOSE DIA.	D BODY DIA.	E MOUNTING SCREW SIZE	F BOLT CIRCLE	G SQUARE	H INTERNAL ROD THD.
5100 (-)	0.656	0.375	3/8 -24	0.875	0.875	10-32	1.250	1.250	1/4 -28
5101 (-)	0.938	0.500	1/2 -20	1.063	1.250	10-32	1.500	1.500	3/8 -24
5102 (-)	1.188	0.625	5/8 -18	1.313	1.500	1/4 -28	2.063	2.000	7/16 -20
5103 (-)	1.500	0.750	3/4 -16	1.625	1.875	5/16 -24	2.250	2.250	1/2 -20

CONFIGURATION B, Double Acting-Single Ended- Both Side Ports

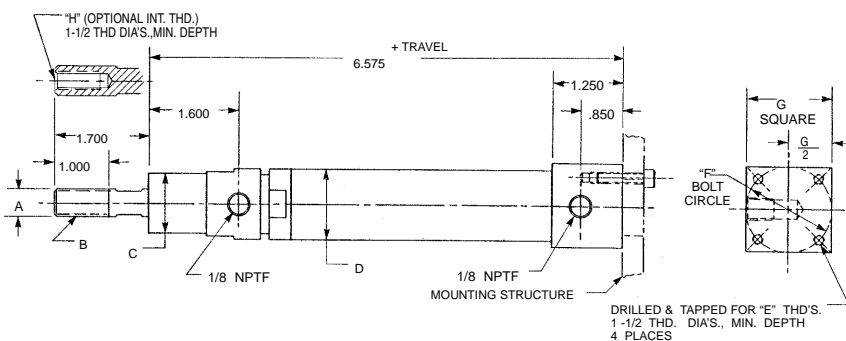

PART NO. & TRAVEL	CYLINDER BORE	A ROD DIA.	B EXTERNAL ROD THD.	C NOSE DIA.	D BODY DIA.	E MOUNTING SCREW SIZE	F BOLT CIRCLE	G SQUARE	H INTERNAL ROD THD.
5104 (-)	0.656	0.375	3/8 -24	0.875	0.875	10-32	1.250	1.250	1/4 -28
5105 (-)	0.938	0.500	1/2 -20	1.063	1.250	10-32	1.500	1.500	3/8 -24
5106 (-)	1.188	0.625	5/8 -18	1.313	1.500	1/4 -28	2.063	2.000	7/16 -20
5107 (-)	1.500	0.750	3/4 -16	1.625	1.875	5/16 -24	2.250	2.250	1/2 -20

CONFIGURATION C, Double Acting-Double Ended- Both Side Ports

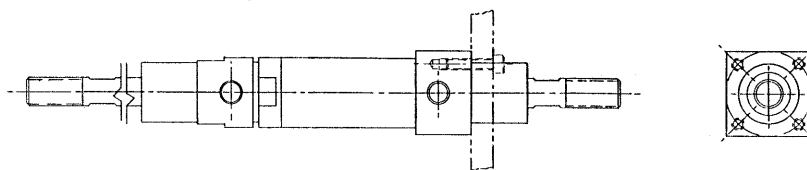

NOTE: SAME AS CONFIGURATION "C" ON DATA SHEET 8041 WHEN MOUNTED END FOR END. PLEASE REFER TO PART NUMBERS 5032 (-), 5033 (-), 5034 (-) & 5035 (-).